



THE EQUALIZER™

NITROGEN ASSISTED DAMPENING SYSTEM

FOR 55 & 60 TON 3+1 SPREAD AXLE
SERIES TRAILERS & AXLE ATTACHMENTS



DUAL 2-SPEED LANDING GEAR

*Your
Transport
Advantage*



LIFT AXLE FOR EASY BACKING



THE EQUALIZER™

NITROGEN ASSISTED DAMPENING SYSTEM

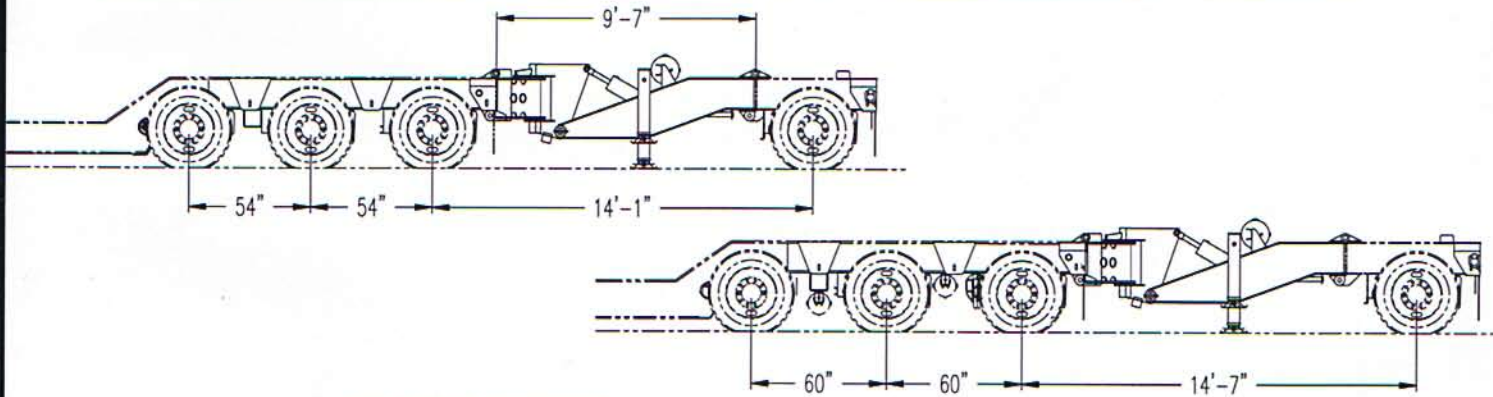

SPECIFICATIONS

- NITROGEN ASSISTED DAMPENING
- HONDA GAS ENGINE POWER PACK STANDARD
- TRANSFERS LOAD VIA HYDRAULICS
- LIFTS LAST AXLE FOR EASY BACKING
- PROVIDES 14'-1" SPREAD WITH 54" AXLE SPACING
- PROVIDES 14'-7" SPREAD WITH 60" AXLE SPACING
- 2 SPEED – DUAL LANDING LEG FOR GREATER STABILITY
- HIGH STRENGTH 100,000 P.S.I. MIN. YIELD STEEL
- SELF TRACKING PIVOT DESIGN
- NO SHIMMING REQUIRED FOR EASE OF OPERATION
- MAKES EMPTY TRAVEL POSSIBLE WITHOUT SHIM REMOVAL
- FOR USE WITH 55SA AND 60SA 3+1 SPREAD AXLE SERIES TRAILER AND AXLE ATTACHMENTS
- ESTIMATED WEIGHT 2,950#

Dealer



NOTE: ALL SPECIFICATIONS SUBJECT TO CHANGE WITHOUT NOTICE. ALL WEIGHTS AND DIMENSIONS APPROXIMATE. SHOWN IN A FULLY LOADED POSITION. PLATFORM HEIGHTS WILL INCREASE IF LOADED AT LESS THAN FULL CAPACITY.

Talbert Manufacturing, Inc.
1628 W. State Road 114
Rensselaer, IN 47978
800-348-5232, Fax 219-866-7060
www.talbertmfg.com
Bulletin #240